

System 71 67 999 00 generator & ignition for classic 2 valve
BMW /6 and /7 motorcycles
=> [€/€](#)
not suitable for R100 (customers report starting problems)

Please note: Larger cc BMW with older e-starter might have starting problems with our systems. The starter does not reach the needed starting revs, the engine does not start. Pushstarted it will however start. Customers with such engines should not buy our systems. For the R100 we have already excluded the R100 for exactly this problem.

Note, not for BMW with lightened flywheel, why is [explained here](#)

System 71 67 999 4K **Special system:** for BMW /6 and /7 with dual plug heads (4
=> [€/€](#) spark plugs)

([base diameter 107mm](#) - important, check!)



Magnet based generator with integrated solid state ignition. Output 12V/[190W](#) DC. Maintenance free, electronic ignition with own power supply from within the system. Replaces the stock 12V alternator (including diode plate and regulator) as well as all ignition parts, be it points or hall element). There is no need for changes on engine casing.

for the /5 and early /6 see system [70 67 999 00](#)

for the R50/2 stock 12V BMW [70 64 999 00](#)

there is a [customer video on this system on youtube](#)



Please note!

- does not support any existing electronic revolution counter. If you want a rev meter, [have a look at our info here.](#)
- has only 190watts (ignition power however additional to that) and offers therefore less electric power than stock alternator
- this is not a tuning system to get more performance. This is a replacement kit for material no longer available, simply to keep the bike running
- the system is not suitable for BMW after the 2 valve series

advantage over original system:

- all parts are new
- you may technically drive without battery ([but note limitations](#))
- full electronic, solid state ignition with automatic ignition advance
- no more wear on points, collector and governor
- no more trouble with damaged rectifiers

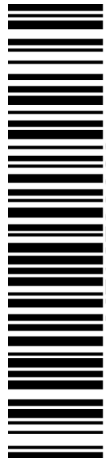

documentation:

- [assembly instructions](#)
- [wiring diagram of the new system](#)
- [wiring detail for connection of new regulator to stock safety relay \(so your BMW had\)](#)
- [parts in the pack \(photo\)](#)

photos:

- [the assembled new system](#) (photo shows the prototype)
- [old and new dynamo side by side](#)
- [the special base for the /6 and /7](#)

- [assembly instructions of the 4-plug-system](#)
- [wiring diagram of the 4-plug-system](#)
- [parts in the pack \(photo\)](#)

- [view at the stator](#)
- [rotor at point of ignition](#)
- [replaces the stock generator](#)

Assembly instructions for systems [70 67 999 00](#) and [71 67 999 00](#)
 the difference between the two is the diameter of the base plate
 only

Version 11.11.2016

If you can install and time a stock ignition and possess basic mechanical skills, you can install a VAPE!

If you never have worked on your ignition, better have it done by someone who knows.

VAPE can not monitor the compliance to those instructions, nor the conditions and methods of installation, operation, usage and maintenance of the system. Improper installation may result in damage to property and possibly even bodily injury. Therefore we assume no responsibility for loss, damage or cost which result from, or are in any way related to, incorrect installation, improper operation, or incorrect use and maintenance. We reserve the right to make changes to the product, technical data or assembly and operating instructions without prior notice.

Please read these instructions fully and carefully before starting work on your motorcycle

Please bear in mind that [any modification of the material as well as own repair attempts which have not been agreed with VAPE may result in a loss of warranty. Do not cut off wires. This leads to a loss of reverse polarity protection and often results in damage to electronics.](#) Also, please take note of the information provided on the information page for this system. Check that what you have bought really corresponds to the motorcycle you have. Wrong ignition settings may damage your engine and even hurt you during kickstart (violent kickbacks). Be careful during the first test runs. If needed change settings to safer values (less advance). During assembly check carefully that the [rotor \(flywheel\) does not touch the stator coils or anything else](#), which may happen due to various circumstances and lead to severe damage.



IMPORTANT:

Designated use

This system is designated to replace stock dynamo/alternator & ignition systems in vintage and classic motorcycles [whose engine characteristics have not been modified aftermarket](#). This system is not a tuning system and it will not bring significant increases in engine output. It does however significantly enhance roadworthiness and comfort by offering better lighting, better function of side indicators and horn and, compared with the aging stock systems, increased reliability. As our system does not tamper with engine characteristics it does not increase emission of gaseous pollutants and noise. In most cases emission of pollutants should even be reduced due to better combustion. If used as designated the system therefore will not normally infringe the existing legal status of the motorcycle (this statement is valid for Germany, for other countries, please check locally against your road licensing regulations). This system is not suitable for use in competition events. If used other than the designated way, warranty will be voided and it might well be that you do not obtain the desired results or, worst you loose legal

roadworthiness.

The charging system is only suitable for use with rechargeable 12V (6V systems 6V) lead-acid batteries with liquide electrolyte or sealed lead-acid batteries, AGM, Gel. It is not suitable for use with nickel-cadmium, nickel-metal-hydride, lithium-ion or any other types of rearchable or non rechargeable batteries.

This is a **replacement system and not a copy of the stock material.** The parts in this system therefore look different and might fit differently (notably ignition coil and regulator) requiring some adaptation by you.

During assembly imperatively start with assy of engine based parts to see that those really fit before you start fitting the external parts. In many cases customers assemble those first and thereby often modify them in breach of warranty which renders them unfit for renewed sale. Replacing old ignition systems is not a matter of taking something from a supermarket shelf as there have been very many types, versions and possibly unknown aftermarket modifications which harbour plenty of room for error.

Our systems are **NOT tested for use with third party electronic devices (such as GPS, mobile phones, LED lighting etc)and may cause damage to such parts.** Possibly existing electronic tachometers will not work with the new system. Read our information for suitable solutions. Possibly existing safety switches and electronic valve controls are not supported. It might be that your motorcycle was originally equipped with an ignition that did limit top speed for legal reasons. The new system does not have such a facility, so check your legal situation beforehand.

If you have no expertise for the installation have it done by an expert or at a specialist's workshop. Improper installation may damage the new system and your motorcycle, possibly even lead to bodily harm.

Before you order a system, please check whether a puller tool for the new rotor is included in the kit. If not, better order it at the same time. You might want to order light bulbs, fuse, horn, flasher unit etc. Never use anything other than the recommended puller tool to pull the new rotor again. Damage to the rotor as a result of use of other tools or methods is not covered by warranty.

The rotor is sensible to blows (including during transport). Before assembly, please always check for damage (on rotor without magnet plastification try to push the magnets aside with your fingers). After impact the glued in magnets might have broken loose, sticking to the rotor solely by magnetic force, so that one does not notice right away. During engine run the damage would be considerable. Before placing

	the rotor onto the engine, please make sure that its magnets have not collected any metal objects such as small screws, nuts and washers. That equally would lead to severe damage.
 Internet	If you have access to the Internet, best view those instructions online. You get larger and better pictures by clicking onto them and possibly updated information. System list at http://www.powerdynamo.biz

You should have received those parts:



- pre-assembled stator unit
- rotor
- electronic advance unit ("Black Box")
- regulator/rectifier
- twin ignition coil
- relay with cables
- rotor bolt M8 with washer
- 3 screws M5
- cables and wire binder

Please note that the sensor (pickup) is only loosely fixed, as you will have to set it to correct gap. Fasten it well after adjustment.



To disengage your new rotor again, you will need a puller M27x1.25 (part-no.: 99 99 799 00 **-Not provided!**).

Note: Never use a claw puller, a hammer or any other device, that will shake the magnets off.

Make sure your motorcycle rests securely, preferably on an elevated work bench and that you have good access to the front of the engine. You will have to turn the front wheel from time to time for better access.

Disconnect your battery and take it out of the motorcycle for the time of work.



Disconnect all cables at the alternator, condenser, points (or hall element), ignition coils, the diode plate and the regulator unit and remove those parts.



As the fixing point of the stock ignition will not be used furthermore, you may remove the parts there, but than make sure the area is oil proof.



Put the pre-assembled stator plate instead of the original alternator onto the engine case.

The sensor (pick-up) will show into some half past one direction. Screw this plate down with the supplied 3 screws M5. Place the screws in the center of the oblong holes for possibly later adjusting the ignition.

Lead the cable upwards through the opening in the rear part of the engine casing.



Have a look at the new rotor. You will find on the circumference some long protrusion and a lasered on line which goes right up to the top where it is marked with a "0".

The elevated sign is there to trigger ignition. However it does not do so when this elevation reaches the sensor, but after it has gone past it as the system needs to calculate the advance based on engine speed (the time the protrusion needs for one passage used as reference).

Ignition will be timed with crankshaft in TDC.

Take the spark plugs out. Place the rotor provisionally onto the crank shaft (without screwing it down there) for using it as a turning knob. Bring the crank shaft into TDC by using the spyhole.

Pull off the rotor again (you will possibly need the a M27x1.25 puller for this) without changing the crank shaft position.

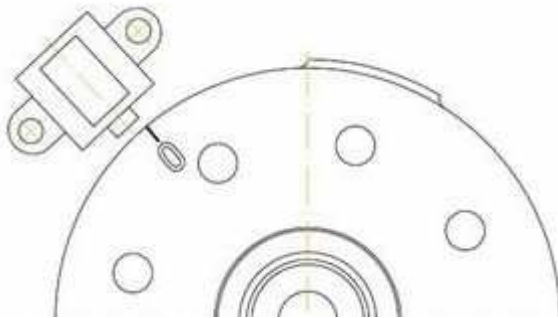

Then place the **rotor back onto the shaft in such a way, that the 0-marking line aligns with the rh edge of the sensor pin as shown in the sketch here.**

Now fasten the rotor with the supplied screw (and washer). Make sure not to change the crank's position during this.

Minor deviations of 1-2mm are harmless (the original centrifugal governor had the some tolerances).



Should you have a rotor that does not yet have the 0-line than you can place this marking easily by yourself as follows:

Cut some strip of paper with **40mm** length, place this on the left side of the trigger sign and mark its end an the circumference with

some marker pen. You than have the needed marking.

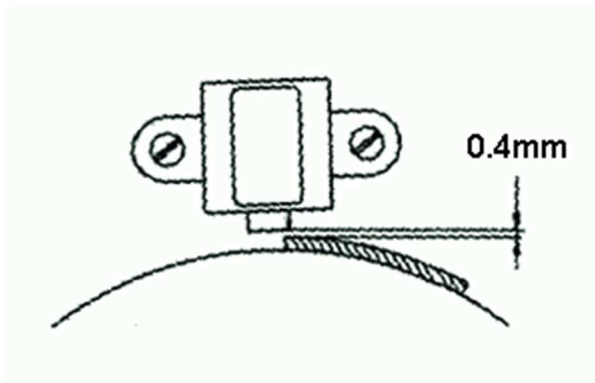

Now, again turn the rotor by hand and check the gap between the sensor and the rotor's elevation. It has to be 0.4 (max 0.5) mm. Adjust it by loosening the sensor's mounting screws and shifting the sensor a little. Do not forget to fasten the screws well after that.

Finally check that the rotor runs freely above the stator plate.

With this the ignition is adjusted.



Mount the electronic regulator/rectifier, the advance unit, the ignition coils and the relay at a convenient place, maybe with a little holding plate (not enclosed) at the frame underneath the tank.

You could position the parts at every other convenient place as long as wires reach there.

Have a look at the small blue switch block at the upper (wire exit) side of the "Black Box" (advance unit). There are 4 little switches for choosing different advance curves.



recommended curve

with all switches to off you have advance change from 9° to 38° at 3000 revs.

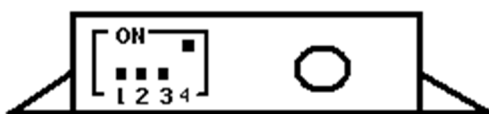

switches 123 to OFF, 4 to on.

This will bring advance of 9° BTDC at idling and

34° at 3.000rpm. Directly at start are 2° after TDC to prevent kickbacks

The new system will be wired between the new parts as explained below.

You will have to modify however the stock wiring a little (besides of taking alternator, condenser, points or hall element, ignition coils, the diode plate and the regulator unit out).

If your BMW had (in /5 and early /6 only we think) a relay to prevent starting into already running engine (Anlasswiederhol Sperre) you need to implement the following changes. If there is no such relay (which please do not confuse with the new cut off relay the VAPE system brings in) please skip the following.

There are 3 connections to modify

- (1) at pin 15 (a green wire to the stock relay), add a wire running to pin 85 of the new switch off relay
- (2) at the pin without number (a blue wire to the stock relay formerly connected to the diode block) connect pin 6 (green/red) of the VAPE regulator (charge control)
- (3) at pin 30 (red wires to stock relay) connect the red from pin 5 of the VAPE regulator (plus output from regulator)

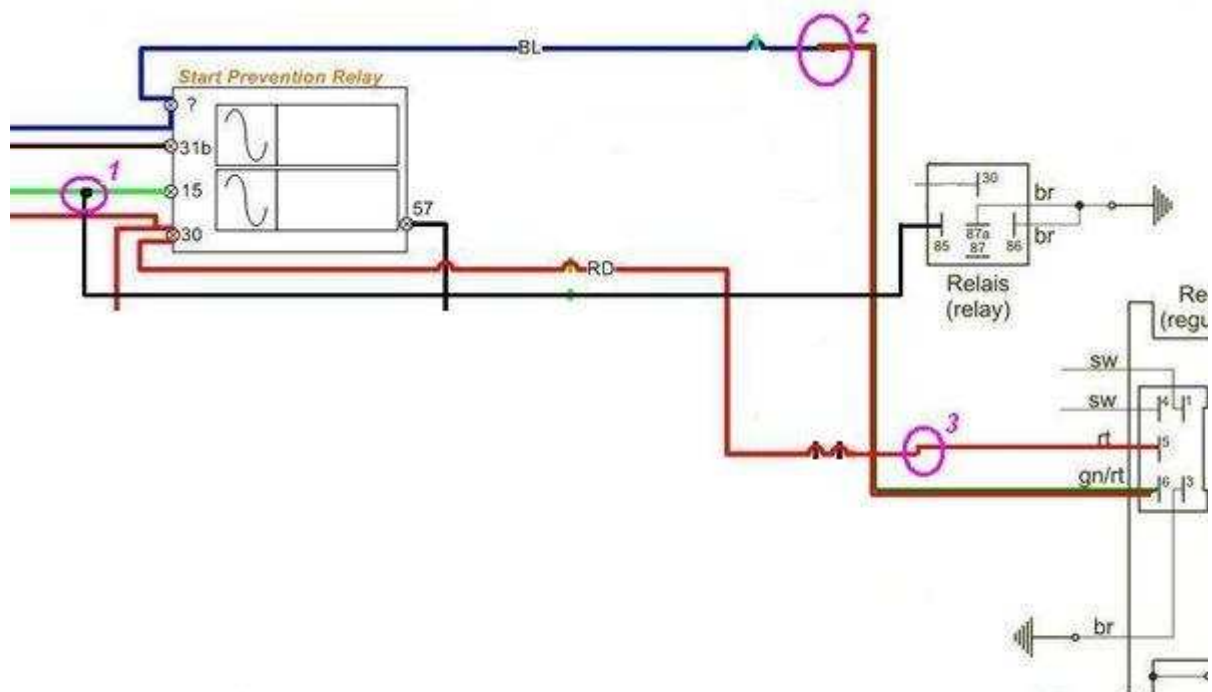

With his arrangement, both the BMW charge control light and the starter prevention relay will function as before.



For a stock wiring diagram [see here](#). Diagram is shown with kind permission from [w6rec.com](#) (note there have been different versions of this)

Connect the parts as shown in the respective wiring diagram!

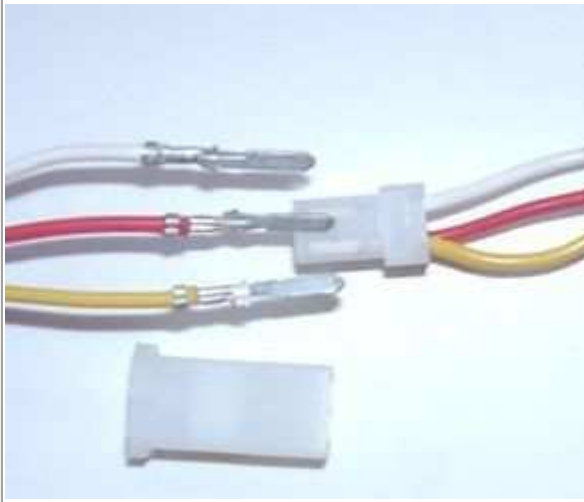
For our [standard DC regulator \(95 22 699 06\)](#), use the [wiring diagram 92xr12](#):
 For our [DC regulator with built in smooting condenser \(73 00 799 50\)](#), use additional the [wiring diagram reg_102](#):

*	<p>To facilitate wire exit through the often small openings in the engine casing, the plastic plug of the generator's wiring that leads to the advance unit have not been put onto the wire terminal. You should place the plug there only once all has been properly installed on the engine side.</p>
*	<div style="display: flex; align-items: flex-start;">  <div style="margin-left: 20px;"> <p>Look for the advance unit with its female plug and the three wires (red, yellow and white).</p> <p>Put the provided 4-position plug housing onto this plug and insert the three wires (red, yellow and white) from the generator. Make sure that the terminals engage securely in the housing and that you connect:</p> <ul style="list-style-type: none"> • red to red • yellow to yellow • white to white </div> </div>
	<p>Should you need (or want) to get the terminals out of the plug housing again, enter a paper clip from front next to the terminals and push the little barb aside. Than pull the wire out.</p>
*	<p>The second plug at the advance (a male plug) will be connected to the plug at the ignition coil. This two plugs can only be connected in one position. Note the changing colour:</p> <ul style="list-style-type: none"> • red to red • white to white • blue/white of the advance unit to yellow of the ignition coil
*	<p>Important! Never run the high tension cable(s) and the cable(s) of the advance unit closely in parallel (say in one shielding). This will trigger back coupling that disturbs ignition and might even damage the advance unit.</p>
*	<p>Connecting VAPE alternator to lighting circuit (via regulator):</p>
*	<div style="display: flex; align-items: flex-start;">  <div style="margin-left: 20px;"> <p>The 2 black wires running from the stator coil carry the voltage for lights, horn, flashers etc. They have nothing to do with ignition.</p> <p>This voltage (something between 10 and 50 volts AC) has however to be stabilized (regulated) and for most uses rectified into direct current (DC) as it primarily is alternating current (AC).</p> <p>For this we offer 2 different regulators:</p> </div> </div>

	Attention: Any confusion between plus and minus (with the DC versions) leads to immediate destruction of the regulator . This will not constitute a warranty case as it is negligence! One can recognize a burnt regulator mostly by its sharp smell.	
*	Regulator type 1: with standard DC regulator (95 22 699 06) , use the wiring diagram 92xr12 :	
*		The new regulator/rectifier has a compact plug with 6 positions, of which <i>one</i> is not used. A female plug cover fitting to this plug is delivered. Into this female plug you have to insert the following wires (which have terminals that snap into the plug):
	The two black cables leading from the generator connect to pins 1/4 of the new regulator (from there equally black wires lead inside the unit). It does not matter which wire connects to which of the both terminals (1/4) as they carry alternating current.
	The new brown cable with the round eye terminal connects pin 3 of the regulator unit (from there equally a brown wire goes inside the unit) with the negative pole of the battery or (in case you drive without battery) to ground (chassis).
	The new red cable with the round eye terminal ... Take care: Wrong polarity will damage the electronics!	... connects to pin 5 of the new regulator (from there equally a red wire goes inside the unit). Here your regulated positive voltage comes out to connect to battery plus, or (in case you drive without battery) to the voltage input terminal of the main switch (ignition lock, German bikes: pin 51/30).
Make sure that you have a 16A-fuse between battery and vehicle circuitry.		
	The green/red wire at pin 6 of the new regulator ... Remark: Until November 2007 this wire has been a single wire outside the compact plug.	... is for the charge control light. You connect there the wire that formerly did run from the control light to the original regulator. Sure that this control only functions with a battery present. Should you drive without battery but still connect the wire, you will see that the light glows even as the generator generates voltage. So without battery, do not connect it.
The charge light control function is based on a transistor switch and is an additional function. Even if that should fail, the regulator might still be in ok working condition. Simple check: have the engine running, turn lights on, disconnect the battery. If you have bright lights the unit is ok.		

<p>* Regulator type 2: with DC regulator with built in smooting condenser (73 00 799 50), use additional the wiring diagram reg_102:</p>	
	<ul style="list-style-type: none"> • the 2 black (sw) wires are the AC input from the alternator (as it is AC it does not matter which black to which black) • the red (rt) wire is the 12V DC output plus • the brown (br) wire is ground, internally connected to housing
<p>Remains the blue (sometimes blue/white) wire at the ignition coil. This is the kill (cut-off) wire.</p> <p>Connected to ground - it will stop ignition!</p> <p>* Note: Should you experience ignition failures, disconnect as a first measure this blue wire. In many cases that will permit you to get mobile again (particulars see: technical help)!</p>	<p>Switch off via separate kill switch (when driving without battery): The relay will not be fitted. The blue(/white) cable of the ignition coil will be connected to a kill switch, closing against ground (a button at the handlebars). Or you mount an ignition lock that has a facility to connect against ground when in OFF position.</p> <p>Battery method: Connect the brown relay wire to good ground. Lead the longer black wire from the relay to the wire that did run previously to a pin carrying voltage when the switch is on (in German bikes: pin 15) and connect it there. Connect the blue wire from pin 30 of the relay to the blue(/white) wire at the new ignition coil. should your battery fail on the road, just disconnect that blue wire and your bike will run again (it will now only not stop by switching off).</p>

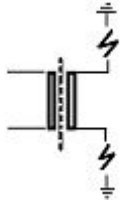
<p>Relay wiring (if used):</p>	<p>The brown wire with the ring terminal from pins 87a und 86 goes to ground.</p> <p>The black wire from pin 85 goes to a main switch terminal carrying voltage if switched on.</p>
<p>Screw the high tension (ignition) cables ...</p> <p>* Please do not use any spark amplifying cables, such as "Nology supercables" or "hot wire". This will disturb the system and possibly damage it.</p>	<p>... into the ignition coil and pull over the rubber seals before mounting the coil (it will be easier).</p> <p>Please do use the cable arriving with the pack and not any old cable.</p>
<p>You will do yourself a favour to treat your bike to new spark plugs and spark plug sockets (preferably some between 0-2kOhm). Plenty of problems are to be traced back to "apparently good" (even completely "brand-new") sparks plugs, terminals and cables.</p> <p>Do not use spark plugs with an intern suppression resistor. NGK (e.g.) offered such spark plugs coded with an "R" (for resistor).</p>	
<p>* </p> <p></p>	<p>In our twin outlet coils both ends of the secondary go to the spark plugs.</p> <p>Typical resistance between both exits is 6.2kOhm. Both exists fire at the same time (as many twin systems do). Sparks will be polarised however at a 180 degrees difference which might manifest when you strobe it.</p>
<p>Ignition will only work correctly if both plug terminals are connected. You may not test one side with the other open (not sitting on the mounted spark plug). This is because (effectively) each exit uses ground from the other. That means also that both plugs are working in serial, adding resistances, so better use low resistance spark plug (resistor) sockets and make sure they are good. If in doubt, measure resistance on a hot socket (warm it up before measuring).</p> <p>Is the flow from ground of one side via spark plug there, via coil, to the other spark plug and its ground interrupted you get no spark - on neither side. If you really want to test only one side, put the HT wire of the other to ground (earth it) than it will work. Sometimes a coil deprived of its ground from the other side searches for a substitute - with some solid fireworks around it to the chassis.</p>	
<p>* Finally - and before installing the battery and before the first kickstart - please re-check carefully all connections and fitments against the wiring diagram. Do check battery and light bulbs for correct voltage (12V).</p>	<p>Should something not work, please consult our trouble-shooting guide on our homepage. As a first step disconnect the blue wire from the coil and re-test.</p>

*	<p>IMPORTANT: During crank shaft repair the dynamo shaft is often machined and gets shorter. The result is a rotor sitting lower, possibly touching now with its rivets the stator coil. The result is a destroyed stator and ignition failure.</p> <p>For more detail and how to check see (online) here.</p>
<p>Important safety and operating information</p>	
#	<p>Safety first! Please observe the general health and safety regulations motor vehicle repair (MVR) as well as the safety information and obligations indicated by the manufacturer of your motorcycle.</p> <p>The timing marks on the material are for general guidance only during first installation. Please check after assembly by suitable means (stroboscope) that settings are correct to prevent damage to the engine or possibly even your health. You alone are responsible for the installation and the correctness of settings.</p>
#	<p>Ignition systems generate high tension! With our material right up to 40,000 Volts! This may, if handled carelessly, not only be painful, but outrightly <u>dangerous</u>. Please do keep a safe distance to the electrode of your spark plug and open high tension cables. Should you need to test spark firing, hold the spark plug socket securely with some well insulating material and push it firmly to solid ground of the engine block.</p> <p>Never pull sparkplug caps when engine is running. Wash your vehicle only with engine at standstill and ignition off.</p>
#	<p>Should you have received in the kit HT cables with a fixed rubber boot(which does not contain a resistor) you might have to use spark plugs with an inbuilt resistor (or replace the cap with one containing a resistor) to comply with your local laws.</p>
#	<p>After installation, please <u>check tightness of all screws, even those preinstalled</u>. If parts get loose during run, there will be inevitably damage to the material. We pre-assemble screws only loosely.</p>
#	<p>Give the newly installed system a chance to work, before you start to check and test values, or what is worse apply changes to it.</p> <p>Our parts have been checked before delivery to you. You will not be able to check much anyway. At any rate do refrain from measuring the electronic components (such as ignition coil, regulator and advance unit). You risk severe damage to the inner electronics there. You will not get any tangible results from the operation anyway. Bear in mind that also your carburetor, your spark plugs and spark plug sockets (even if completely new) might be the reason for malfunction.</p> <p>The general experience with our systems is that the carburetor will have to be re-adjusted to lower settings. Should the system not start after assembly, first disconnect the blue (or blue/white) cut-off wire directly at the ignition coil (or in some cases advance unit) to eliminate any malfunction in the cut-off circuitry. Check ground connections carefully, make sure there is a good electrical connection between frame and engine block.</p> <p>In case of troubles, please consult our Knowledge Base first before you send off the material to us for checking</p>
#	<p>The spark of classic, points based ignition systems has with about 10,000 Volts comparatively little energy and looks therefore yellow and fat (which however makes it highly visible). The spark from our system is a high energy spark with up to 40,000 Volts and therefore is needle thin focused in form, and blue in colour, which makes it not so</p>

	<p>visible. Furthermore you get spark only at kick-start operated speeds and not by pushing the kick-lever down slowly with your hand (as you might get with battery based ignitions).</p>
#	<p>Systems using a twin outlet ignition coils have a few peculiarities. Please observe that during tests on one side, the other has either to be connected to an fitted spark plug or securely earthed/grounded. Otherwise there will be no spark on either side. Also with such open exits long and dangerous sparks may fly all over the coil.</p>
#	<p>Never do electric arc welding on the bike without completely disconnecting all parts containing semiconductors (ignition coil, regulator, advance) stator and rotor need not be taken off. The same is true for soldering. Before touching electronics disconnect the soldering iron from mains! Never use copper putty on spark plugs.</p>
#	<p>Electronics are very sensitive to wrong polarity. After work on the system, do check correct polarity of the battery and the regulator. Wrong polarity creates short circuits and will destroy the regulator, the ignition coil and the advance unit. As a rule, wiring will always be colour to colour. Instances, where colour jumps between wires are expressly mentioned in our instructions.</p>
#	<p>When you handle the new rotor, take care not to damage its magnets. Refrain from direct blows to the circumference of the rotor. When transporting never put the rotor over the stator. Observe our information relative to transport of the material.</p>
#	<p>Do not use spark plug sockets with a resistance of more than 5kOhm. Better use 1 or 2kOhm ones. Bear in mind that spark plug sockets do age and thereby increase their internal resistance. Should an engine start up only when cold, a defective spark plug socket and/or spark plug is very probably the cause. In case of problems check high tension cables too. Never use carbon fibre HT-cables, never use so called "hot wires" which promise to increase spark.</p>
#	<p>It is a good idea to cover the rotor in a thin layer of oil to reduce the risk of corrosion.</p>
#	<p>Never use a claw puller or a hammer to disengage the rotor. Its magnets might become loose in the event. We offer a special puller for disengaging the new rotor again (see assembly instruction)!</p>
#	<p>Should the motorcycle not be in use for some longer period, please disconnect the battery (so existing) to prevent current bleeding through the diodes of the regulator. Though, even a disconnected battery will empty itself after a while.</p>
#	<p>Please do observe these remarks, but at the same time, don't be afraid of the installation process. Remember, that before you, thousands of other customers have successfully installed the system. <i>Enjoy driving your bike with its new electric heart!</i></p>

Schaltplan 92xr12 (wiring diagram)

